



US Micro Products
Electronic Products for the OEM

TFT-LCD PRODUCT SPECIFICATION

Manufactured by:



PART NUMBER:	USMP-M280DGJ-L30
DESCRIPTION:	28" TFT LCD with 3840 x 2160 (4K UHD) resolution and 51 pins 8 lane -V by 1 interface.

ISSUE DATE	APPROVED BY (Customer Use Only)	CHECKED BY	PREPARED BY
PROPRIETARY NOTE:	THIS SPECIFICATION IS THE PROPERTY OF US MICRO PRODUCTS AND SHALL NOT BE REPRODUCED OR COPIED WITHOUT THE WRITTEN PERMISSION OF US MICRO PRODUCTS AND MUST BE RETURNED TO US MICRO PRODUCTS UPON ITS REQUEST.		

PRODUCT SPECIFICATION

Doc. Number :

- Tentative Specification
- Preliminary Specification
- Approval Specification

MODEL NO.: M280DGJ
SUFFIX: L30

Customer:	
APPROVED BY	SIGNATURE
<u>Name / Title</u> Note Product Version A1/A2	_____ _____
Please return 1 copy for your confirmation with your signature and comments.	

Approved By	Checked By	Prepared By
吳柏勳	梁永祥	黃世中

CONFIDENTIAL

CONTENTS

1. GENERAL DESCRIPTION	5
1.1 OVERVIEW	5
1.2 GENERAL SPECIFICATIONS	5
2. MECHANICAL SPECIFICATIONS	5
3. ABSOLUTE MAXIMUM RATINGS	5
3.1 ABSOLUTE RATINGS OF ENVIRONMENT	5
3.2 ELECTRICAL ABSOLUTE RATINGS	6
3.2.1 TFT LCD MODULE	6
3.2.2 BACKLIGHT UNIT	6
4. ELECTRICAL SPECIFICATIONS	7
4.1 FUNCTION BLOCK DIAGRAM	7
4.2. INTERFACE CONNECTIONS	7
4.3 ELECTRICAL CHARACTERISTICS	8
4.3.1 LCD ELETRONICS SPECIFICATION	8
4.3.2 Vcc Power Dip Condition	8
4.3.3 BACKLIGHT UNIT	8
4.3.4 LIGHTBAR Connector Pin Assignment:	8
4.4 V by One INPUT SIGNAL SPECIFICATIONS	8
4.4.1 V by One DATA MAPPING TABLE	8
4.4.2 COLOR DATA INPUT ASSIGNMENT	8
4.5 DISPLAY TIMING SPECIFICATIONS	8
4.6 POWER ON/OFF SEQUENCE	8
5. OPTICAL CHARACTERISTICS	8
5.1 TEST CONDITIONS	8
5.2 OPTICAL SPECIFICATIONS	8
6. RELIABILITY TEST ITEM	8
7. PACKING	8
7.1 PACKING SPECIFICATIONS	8
7.2 PACKING METHOD	8
7.3 PALLET	8
7.4 UN-PACKING METHOD	8
8. INX MODULE LABEL	8
9. PRECAUTIONS	8
9.1 ASSEMBLY AND HANDLING PRECAUTIONS	8
9.2 STORAGE PRECAUTIONS	8

CONFIDENTIAL

PRODUCT SPECIFICATION

9.3 OPERATION PRECAUTIONS	8
9.4 SAFETY PRECAUTIONS	8
9.5 SAFETY STANDARDS	8
9.6 OTHER	8
Appendix 1. SYSTEM COVER DESIGN NOTICE	8
Appendix 2. OUTLINE DRAWING	8

CONFIDENTIAL

PRODUCT SPECIFICATION

REVISION HISTORY

Version	Date	Page	Description
0.0	4.22, 2013	All	Tentative Spec Ver.0.0 was first issued.
0.1	4.25, 2013	5	Pixel Pitch: 0.32 (H) x 0.32 (V) -> 0.16 (H) x 0.16 (V)
0.2	6.25, 2013	4.3.1	Comment Power Supply Current value

CONFIDENTIAL

1. GENERAL DESCRIPTION

1.1 OVERVIEW

M280DGJ-L30 is a 28.0" TFT Liquid Crystal Display module with WLED Backlight unit and 51 pins 8 lane –V by 1 interface. This module supports 3840 x 2160 UHD mode and can display up to 1.073G colors. The converter module for Backlight is not built in.

1.2 GENERAL SPECIFICATIONS

Item	Specification	Unit	Note
Screen Size	648.9 (H) X 369.3 (V)	mm	
Driver Element	a-si TFT active matrix	-	-
Pixel Number	3840 x R.G.B. x 2160	pixel	-
Pixel Pitch	0.16 (H) x 0.16 (V)	mm	-
Pixel Arrangement	RGB vertical stripe	-	-
Display Colors	1.073G	color	-
TCO	(TCO 6.0 compliance)		
Transmissive Mode	Normally White	-	-
Surface Treatment	AG type, 3H hard coating, Haze 25	-	-
Luminance, White	300	Cd/m2	
Power Consumption	Total (29.32) W(Typ.) @ cell (7) W(Typ.), BL (22.32)W(Typ.)		(1)

Note (1) The specified power consumption : Total= cell (reference 4.3.1)+BL (reference 4.3.3)

2. MECHANICAL SPECIFICATIONS

Item		Min.	Typ.	Max.	Unit	Note
Module Size	Horizontal (H)	648.4	648.9	649.4	mm	(1)
	Vertical (V)	368.8	369.3	369.8	mm	
	Thickness (T)	19.35	19.85	20.35	mm	
Bezel Area	Horizontal	626.43	626.93	627.43	mm	
	Vertical	346.78	347.28	347.78	mm	
Active Area	Horizontal	-	620.93	-	mm	
	Vertical	-	341.28	-	mm	
Weight		-	(2910)	(3010)	g	

Note (1) Please refer to the attached drawings for more information of front and back outline dimensions.

3. ABSOLUTE MAXIMUM RATINGS

3.1 ABSOLUTE RATINGS OF ENVIRONMENT

Item	Symbol	Value		Unit	Note
		Min.	Max.		
Storage Temperature	TST	-20	60	°C	(1)
Operating Ambient Temperature	TOP	0	50	°C	(1), (2)

Note (1)

(a) 90 %RH Max. (Ta <= 40 °C).

(b) Wet-bulb temperature should be 39 °C Max. (Ta > 40 °C).

(c) No condensation.

CONFIDENTIAL

Note (2) The temperature of panel surface should be 0 °C min. and 60 °C max.

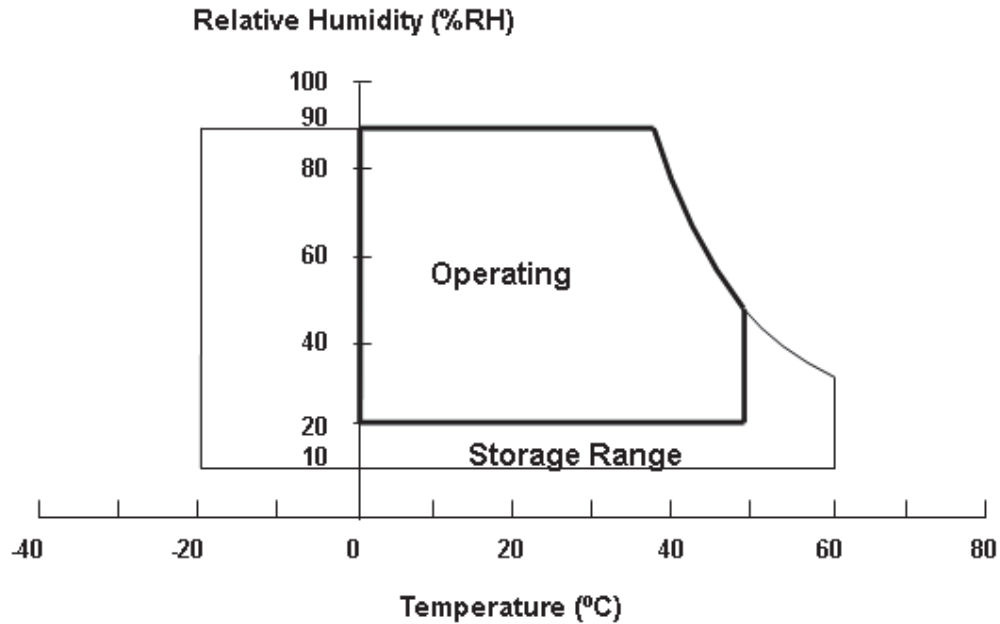

3.2 ELECTRICAL ABSOLUTE RATINGS

3.2.1 TFT LCD MODULE

Item	Symbol	Value		Unit	Note
		Min.	Max.		
Power Supply Voltage	VCCS	-0.3	13.5.	V	(1)
Logic Input Voltage	VIN	-0.3	3.6	V	

3.2.2 BACKLIGHT UNIT

Item	Symbol	Value			Unit	Note
		Min.	Typ	Max.		
LED Forward Current Per Input Pin	IF	0	(150)	(160)	mA	(1), (2) Duty=100%

Note (1) Permanent damage to the device may occur if maximum values are exceeded. Function operation should be restricted to the conditions described under Normal Operating Conditions.

Note (2) Specified values are for input pin of LED light bar at $T_a=25\pm 2$ °C (Refer to 4.3.3 and 4.3.4 for further information).

CONFIDENTIAL

4. ELECTRICAL SPECIFICATIONS

4.1 FUNCTION BLOCK DIAGRAM

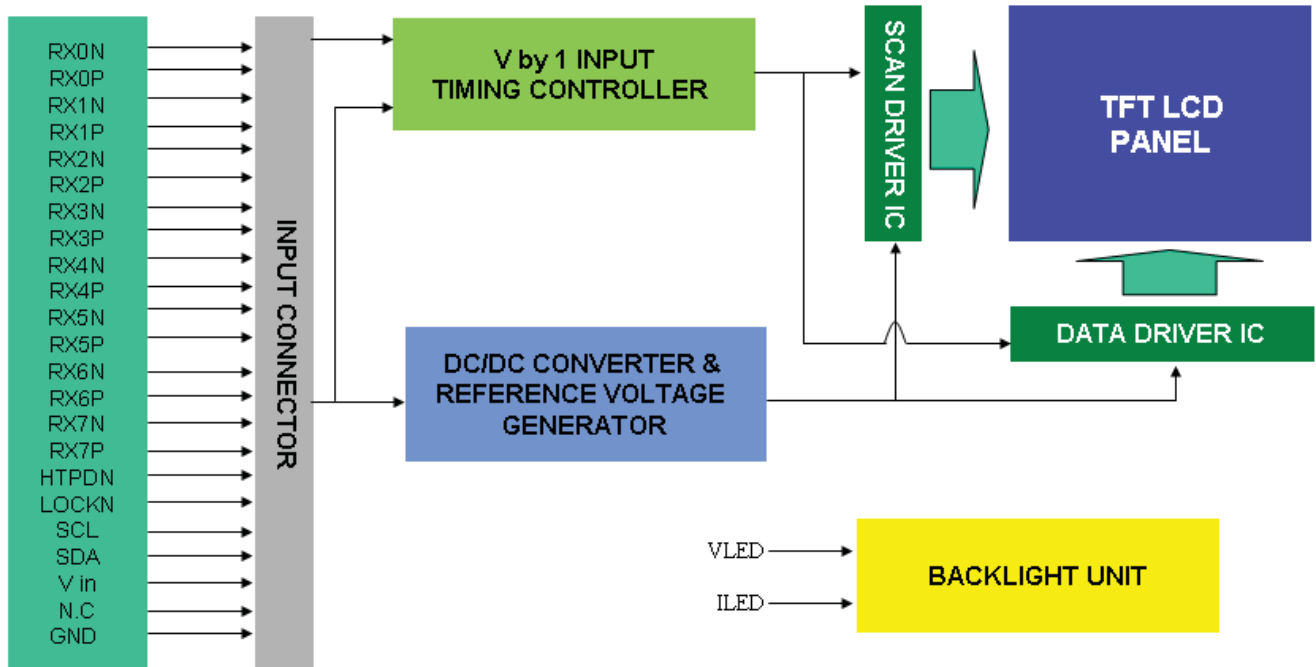

4.2. INTERFACE CONNECTIONS

PIN ASSIGNMENT

Pin	Name	Description
1	Vin	Power input (+12V)
2	Vin	Power input (+12V)
3	Vin	Power input (+12V)
4	Vin	Power input (+12V)
5	Vin	Power input (+12V)
6	Vin	Power input (+12V)
7	Vin	Power input (+12V)
8	Vin	Power input (+12V)
9	N.C.	No Connection
10	GND	Ground
11	GND	Ground
12	N.C.	No Connection
13	N.C.	INX internal use, please keep it in open and don't floating.
14	N.C.	No Connection
15	N.C.	INX internal use, please keep it in open and don't floating.
16	N.C.	INX internal use, please keep it in open and don't floating.
17	N.C.	INX internal use, please keep it in open and don't floating.
18	N.C.	No Connection
19	SCL	I2C Serial Clock
20	SDA	I2C Data
21	N.C.	INX internal use, please keep it in open and don't floating.
22	N.C.	INX internal use, please keep it in open and don't floating.
23	N.C.	No Connection

CONFIDENTIAL

Pin	Name	Description
24	N.C	INX internal use, please keep it in open and don't floating.
25	HTPDN	Hot plug detect output, Open drain.
26	LOCKN	Lock detect output, Open drain.
27	GND	Ground
28	RX0N	First Pixel Negative V by One differential data input Lan 0.
29	RX0P	First Pixel Positive V by One differential data input Lan 0.
30	GND	Ground
31	RX1N	Second Pixel Negative V by One differential data input Lan 1.
32	RX1P	Second Pixel Positive V by One differential data input Lan 1.
33	GND	Ground
34	RX2N	Third Pixel Negative V by One differential data input Lan 2.
35	RX2P	Third Pixel Positive V by One differential data input Lan 2.
36	GND	Ground
37	RX3N	4th Pixel Negative V by One differential data input Lan 3.
38	RX3P	4th Pixel Positive V by One differential data input Lan 3.
39	GND	Ground
40	RX4N	5th Pixel Negative V by One differential data input Lan 4.
41	RX4P	5th Pixel Positive V by One differential data input Lan 4.
42	GND	Ground
43	RX5N	6th Pixel Negative V by One differential data input Lan 5.
44	RX5P	6th Pixel Positive V by One differential data input Lan 5.
45	GND	Ground
46	RX6N	7th Pixel Negative V by One differential data input Lan 6.
47	RX6P	7th Pixel Positive V by One differential data input Lan 6.
48	GND	Ground
49	RX7N	8th Pixel Negative V by One differential data input Lan 7.
50	RX7P	8th Pixel Positive V by One differential data input Lan 7.
51	GND	Ground

Connector Information

Item	Description
Manufacturer	FCN/ P-TWO
Type part number	FCN: WF23-402-5133 P-TWO: 187059-51221
User's Mating housing part number	JAE: FI-RE51HL

*Notice: There would be compatible issues if not using the indicated connectors in the matching list.

Note (1) The first pixel is odd.

Note (2) Input signal of even and odd clock should be the same timing.

CONFIDENTIAL

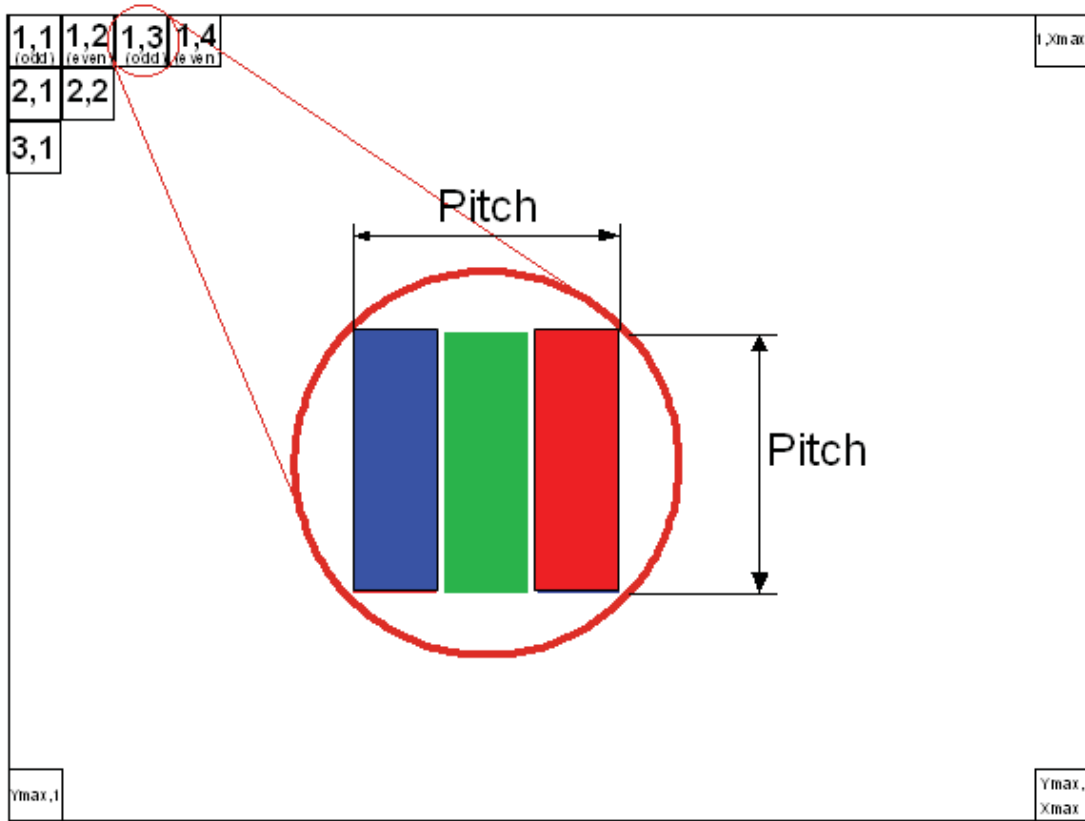

CONFIDENTIAL

4.3 ELECTRICAL CHARACTERISTICS

4.3.1 LCD ELETRONICS SPECIFICATION

Parameter	Symbol	Value			Unit	Note	
		Min.	Typ.	Max.			
Power Supply Voltage	V _{CC}	10.8	12	13.2	V	-	
Ripple Voltage	V _{RP}	-	-	TBD	mV	-	
Rush Current	I _{RUSH}	-	TBD	TBD	A	(2)	
Power Supply Current	White	-	535	635.7	A	(3)a	
	Black	-	519.6	617	A	(3)b	
	Horizontal Stripe	-	969.6	1163.5	A	(3)c	
Power Consumption	PLCD	-	(7)	TBD	Watt	(4)	
V-by-One interface	Differential Input High Threshold Voltage	V _{TH}	-	-	50	mV	
	Differential Input Low Threshold Voltage	V _{TL}	-50	-	-	mV	
	Terminating Resistor	RT	80	100	120	ohm	

Note (1) The ambient temperature is Ta = 25 ± 2 °C.

Note (2) Measurement Conditions:

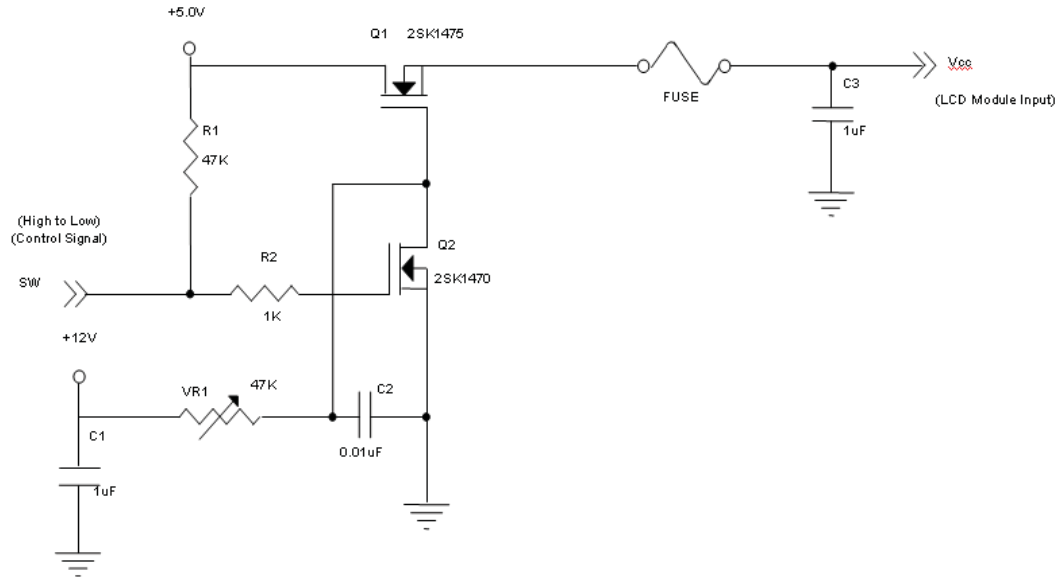

V_{CC} rising time is 470μs

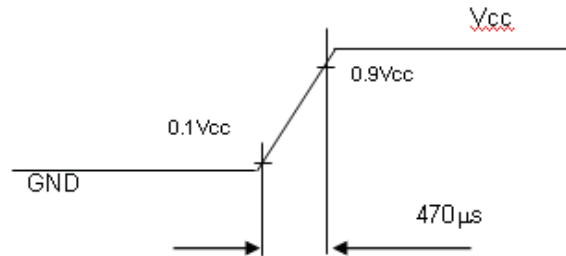

CONFIDENTIAL

Note (3) The specified power supply current is under the conditions at $V_{cc} = 12\text{ V}$, $T_a = 25 \pm 2\text{ }^\circ\text{C}$, $F_r = 60\text{ Hz}$, whereas a power dissipation check pattern below is displayed.

a. White Pattern



Active Area

b. Black Pattern



Active Area

c. Vertical Stripe Pattern

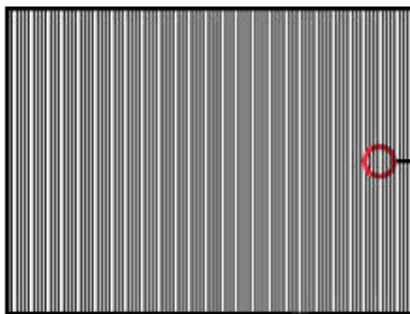

Active Area

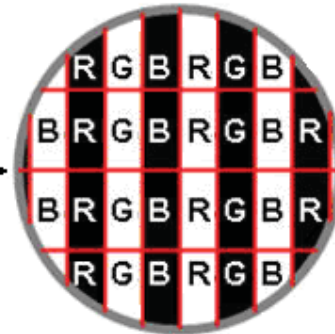

Note (4) The power consumption is specified at the pattern with the maximum current.

CONFIDENTIAL

4.3.2 Vcc Power Dip Condition

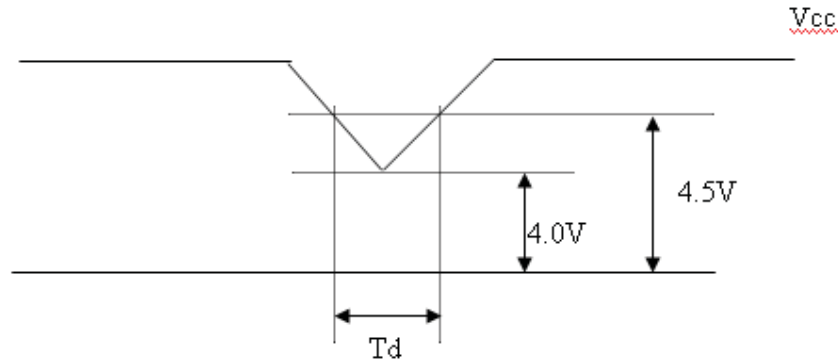

Dip condition: $4.0 \leq V_{cc} \leq 4.5$, $T_d \leq 20\text{ms}$

4.3.3 BACKLIGHT UNIT

Parameter	Symbol	Value			Unit	Note
		Min.	Typ.	Max.		
LED Light Bar Input Voltage Per Input Pin	VPIN	-	(37.2)	(39.6)	V	(1), Duty=100%, IPIN=100mA
LED Light Bar Current Per Input Pin	IPIN	-	(150)	(160)	mA	(1), (2) Duty=100%
LED Life Time	LLED	40000			Hrs	(3)
Power Consumption	PBL	-	(22.32)	(25.34)	W	(1) Duty=100%, IPIN=100mA

Note (1) LED light bar input voltage and current are measured by utilizing a true RMS multimeter as shown below:

Note (2) $PBL = IPIN \times VPIN \times (4)$ input pins.

Note (3) The lifetime of LED is defined as the time when LED packages continue to operate under the conditions at $T_a = 25 \pm 2 \text{ }^\circ\text{C}$ and $I = (150)\text{mA}$ (per chip) until the brightness becomes $\leq 50\%$ of its original value.

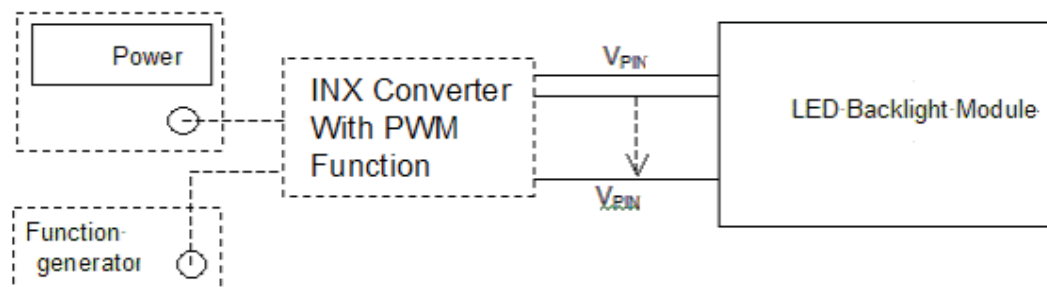

CONFIDENTIAL

4.3.4 LIGHTBAR Connector Pin Assignment:

(1) Connector Information:

Item	Description
Manufacturer	FCN/ Entery/ CviLux
Type part number	WM13-406-063N(FCN) / 3707K-Q06N-08L(Entery) / CI1406M1HRK-NH(CviLux)
Mating housing part number	WF1300106-B (FCN) / H112K-P06N-01B (Entery) / M001-E11N-00R (Entery) / CI1406SL000-NH (CviLux).

*Notice: There would be compatible issues if not using the indicated connectors in the matching list.

(2) LB Connector drawing:

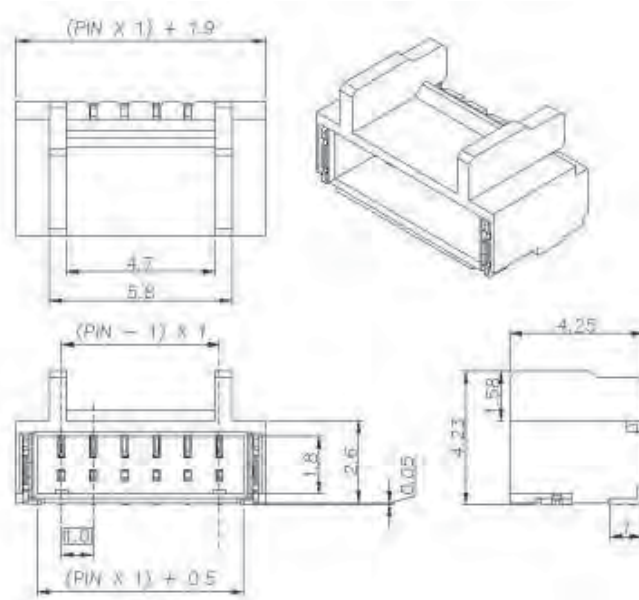

Pin number	Description
1	Cathode of LED string1
2	Cathode of LED string2
3	VLED
4	VLED
5	Cathode of LED string3
6	Cathode of LED string4

CONFIDENTIAL

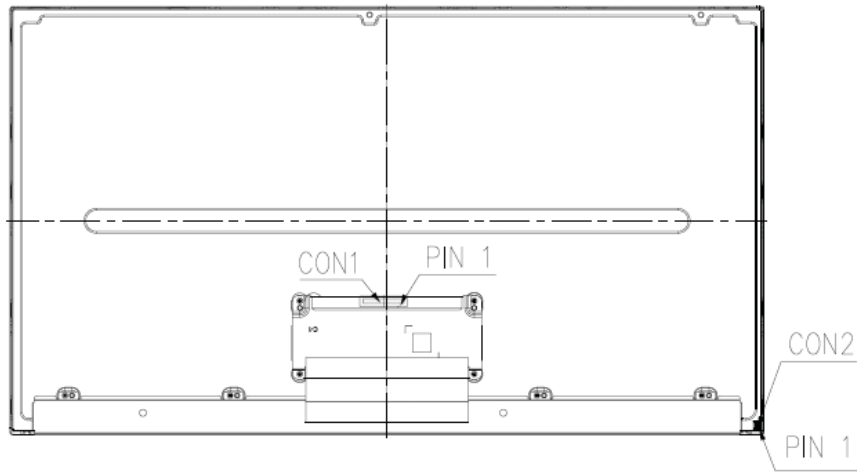

4.4 V by One INPUT SIGNAL SPECIFICATIONS

4.4.1 V by One DATA MAPPING TABLE

Lan	Data Stream
Lan 0	1, 9, 17,, 3825, 3833
Lan 1	2, 10, 18,, 3826, 3834
Lan 2	3, 11, 19,, 3827, 3835
Lan 3	4, 12, 20,, 3828, 3836
Lan 4	5, 13, 21,, 3829, 3837
Lan 5	6, 14, 22,, 3830, 3838
Lan 6	7, 15, 23,, 3831, 3839
Lan 7	8, 16, 24,, 3832, 3840

CONFIDENTIAL

4.4.2 COLOR DATA INPUT ASSIGNMENT

The brightness of each primary color (red, green and blue) is based on the **10-bit** gray scale data input for the color. The higher the binary input, the brighter the color. The table below provides the assignment of color versus data input.

Color	Data Signal																																							
	Red										Green						BLUE																							
	R9	R8	G7	G6	R5	R4	R3	R2	R1	R0	G9	G8	G7	G6	G5	G4	G3	G2	G1	G0	B9	B8	B7	B6	B5	B4	B3	B2	B1	B0										
Basic Colors	Black	0	0	0	0	0	0	0	0	0	0	0	0	0	0	0	0	0	0	0	0	0	0	0	0	0	0	0	0	0	0	0	0	0	0	0	0	0	0	0
	Red	1	1	1	1	1	1	1	1	1	1	1	1	0	0	0	0	0	0	0	0	0	0	0	0	0	0	0	0	0	0	0	0	0	0	0	0	0	0	0
	Green	0	0	0	0	0	0	0	0	0	0	0	1	1	1	1	1	1	1	1	0	0	0	0	0	0	0	0	0	0	0	0	0	0	0	0	0	0	0	0
	Blue	0	0	0	0	0	0	0	0	0	0	0	0	0	0	0	0	0	0	0	0	0	0	0	0	0	0	0	0	0	1	1	1	1	1	1	1	1	1	1
	Cyan	0	0	0	0	0	0	0	0	0	0	1	1	1	1	1	1	1	1	1	0	0	0	0	0	0	0	0	0	0	0	0	0	0	0	0	0	0	0	0
	Magenta	1	1	1	1	1	1	1	1	1	1	0	0	0	0	0	0	0	0	0	1	1	1	1	1	1	1	1	1	1	0	0	0	0	0	0	0	0	0	0
	Yellow	1	1	1	1	1	1	1	1	1	1	1	1	1	1	1	1	1	1	1	0	0	0	0	0	0	0	0	0	0	0	0	0	0	0	0	0	0	0	0
	White	1	1	1	1	1	1	1	1	1	1	1	1	1	1	1	1	1	1	1	0	0	0	0	0	0	0	0	0	0	0	0	0	0	0	0	0	0	0	0
Gray Scale Of Red	Red(0) / Dark	0	0	0	0	0	0	0	0	0	0	0	0	0	0	0	0	0	0	0	0	0	0	0	0	0	0	0	0	0	0	0	0	0	0	0	0	0	0	
	Red(1)	0	0	0	0	0	0	0	0	0	0	1	0	0	0	0	0	0	0	0	0	0	0	0	0	0	0	0	0	0	0	0	0	0	0	0	0	0	0	
	Red(2)	0	0	0	0	0	0	0	0	0	1	0	0	0	0	0	0	0	0	0	0	0	0	0	0	0	0	0	0	0	0	0	0	0	0	0	0	0	0	
	⋮	⋮	⋮	⋮	⋮	⋮	⋮	⋮	⋮	⋮	⋮	⋮	⋮	⋮	⋮	⋮	⋮	⋮	⋮	⋮	⋮	⋮	⋮	⋮	⋮	⋮	⋮	⋮	⋮	⋮	⋮	⋮	⋮	⋮	⋮	⋮	⋮	⋮	⋮	
	Red(1021)	1	1	1	1	1	1	1	1	1	0	1	0	0	0	0	0	0	0	0	0	0	0	0	0	0	0	0	0	0	0	0	0	0	0	0	0	0	0	
	Red(1022)	1	1	1	1	1	1	1	1	1	1	0	0	0	0	0	0	0	0	0	0	0	0	0	0	0	0	0	0	0	0	0	0	0	0	0	0	0	0	
	Red(1023)	1	1	1	1	1	1	1	1	1	1	0	0	0	0	0	0	0	0	0	0	0	0	0	0	0	0	0	0	0	0	0	0	0	0	0	0	0	0	
	⋮	⋮	⋮	⋮	⋮	⋮	⋮	⋮	⋮	⋮	⋮	⋮	⋮	⋮	⋮	⋮	⋮	⋮	⋮	⋮	⋮	⋮	⋮	⋮	⋮	⋮	⋮	⋮	⋮	⋮	⋮	⋮	⋮	⋮	⋮	⋮	⋮	⋮	⋮	
Gray Scale Of Green	Green(0) / Dark	0	0	0	0	0	0	0	0	0	0	0	0	0	0	0	0	0	0	0	0	0	0	0	0	0	0	0	0	0	0	0	0	0	0	0	0	0	0	
	Green(1)	0	0	0	0	0	0	0	0	0	0	0	0	0	0	0	0	0	0	0	0	0	0	0	0	0	0	0	0	1	0	0	0	0	0	0	0	0	0	
	Green(2)	0	0	0	0	0	0	0	0	0	0	0	0	0	0	0	0	0	1	0	0	0	0	0	0	0	0	0	0	0	0	0	0	0	0	0	0	0	0	
	⋮	⋮	⋮	⋮	⋮	⋮	⋮	⋮	⋮	⋮	⋮	⋮	⋮	⋮	⋮	⋮	⋮	⋮	⋮	⋮	⋮	⋮	⋮	⋮	⋮	⋮	⋮	⋮	⋮	⋮	⋮	⋮	⋮	⋮	⋮	⋮	⋮	⋮	⋮	
	Green(1021)	0	0	0	0	0	0	0	0	0	0	1	1	1	1	1	1	1	0	1	0	0	0	0	0	0	0	0	0	0	0	0	0	0	0	0	0	0	0	
	Green(1022)	0	0	0	0	0	0	0	0	0	0	1	1	1	1	1	1	1	1	0	0	0	0	0	0	0	0	0	0	0	0	0	0	0	0	0	0	0	0	
	Green(1023)	0	0	0	0	0	0	0	0	0	0	1	1	1	1	1	1	1	1	0	1	0	0	0	0	0	0	0	0	0	0	0	0	0	0	0	0	0	0	
	⋮	⋮	⋮	⋮	⋮	⋮	⋮	⋮	⋮	⋮	⋮	⋮	⋮	⋮	⋮	⋮	⋮	⋮	⋮	⋮	⋮	⋮	⋮	⋮	⋮	⋮	⋮	⋮	⋮	⋮	⋮	⋮	⋮	⋮	⋮	⋮	⋮	⋮	⋮	
Gray Scale Of Blue	Blue(0) / Dark	0	0	0	0	0	0	0	0	0	0	0	0	0	0	0	0	0	0	0	0	0	0	0	0	0	0	0	0	0	0	0	0	0	0	0	0	0	0	
	Blue(1)	0	0	0	0	0	0	0	0	0	0	0	0	0	0	0	0	0	0	0	0	0	0	0	0	0	0	0	0	0	0	0	0	0	0	0	0	0	1	
	Blue(2)	0	0	0	0	0	0	0	0	0	0	0	0	0	0	0	0	0	0	0	0	0	0	0	0	0	0	0	0	0	0	0	0	0	0	0	0	0	1	
	⋮	⋮	⋮	⋮	⋮	⋮	⋮	⋮	⋮	⋮	⋮	⋮	⋮	⋮	⋮	⋮	⋮	⋮	⋮	⋮	⋮	⋮	⋮	⋮	⋮	⋮	⋮	⋮	⋮	⋮	⋮	⋮	⋮	⋮	⋮	⋮	⋮	⋮	⋮	
	Blue(1021)	0	0	0	0	0	0	0	0	0	0	0	0	0	0	0	0	0	0	0	0	1	1	1	1	1	1	1	0	1	1	1	1	1	1	1	1	0	1	
	Blue(1022)	0	0	0	0	0	0	0	0	0	0	0	0	0	0	0	0	0	0	0	0	1	1	1	1	1	1	1	1	1	1	1	1	1	1	1	1	1	0	
	Blue(1023)	0	0	0	0	0	0	0	0	0	0	0	0	0	0	0	0	0	0	0	0	1	1	1	1	1	1	1	1	1	1	1	1	1	1	1	1	1	1	
	⋮	⋮	⋮	⋮	⋮	⋮	⋮	⋮	⋮	⋮	⋮	⋮	⋮	⋮	⋮	⋮	⋮	⋮	⋮	⋮	⋮	⋮	⋮	⋮	⋮	⋮	⋮	⋮	⋮	⋮	⋮	⋮	⋮	⋮	⋮	⋮	⋮	⋮	⋮	

Note (1) 0: Low Level Voltage, 1: High Level Voltage

CONFIDENTIAL

4.5 DISPLAY TIMING SPECIFICATIONS

The input signal timing specifications are shown as the following table and timing diagram.

Signal	Item	Symbol	Min.	Typ.	Max.	Unit	Note
V by One	Frequency	Fc	TBD	TBD	TBD	MHz	-
	Period	Tc	TBD	TBD	TBD	ns	-
	Intra-Pair skew		-0.3	-	0.3	ns	(1)
	Inter-Pair skew		-5	-	5	ps	(2)
	Spread spectrum modulation range	F _{clk_{in}_mod}	F _{clk_{in}} -0.5%	-	F _{clk_{in}} +0.5%	MHz	(3)
	Spread spectrum modulation frequency	F _{SSM}	-	-	30	KHz	
Vertical Display Term	Frame Rate	Fr	57.5	60	62.5	Hz	Tv=Tvd+Tvb
	Total	Tv	TBD	2250	TBD	Th	-
	Active Display	Tvd	2160	2160	2160	Th	-
	Blank	Tvb	TBD	90	TBD	Th	-
Horizontal Display Term	Total	Th	TBD	550	TBD	Tc	Th=Thd+Thb
	Active Display	Thd	480	480	480	Tc	-
	Blank	Thb	TBD	70	TBD	Tc	-

Note: Because this module is operated by DE only mode, Hsync and Vsync input signals are ignored.

INPUT SIGNAL TIMING DIAGRAM

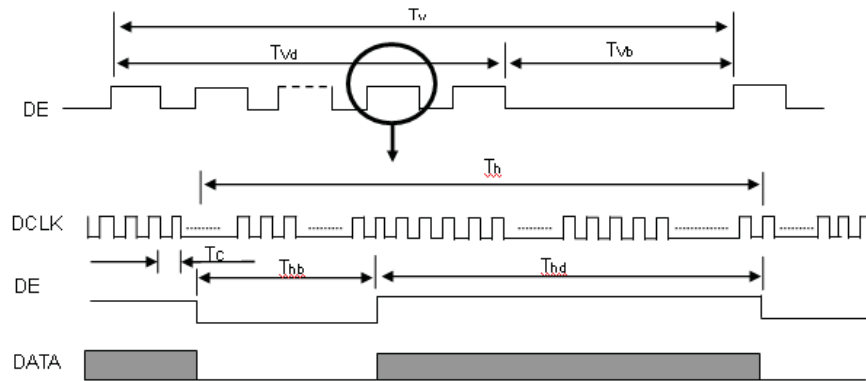

CONFIDENTIAL

Note (1) V-by-One HS Intra-pair skew

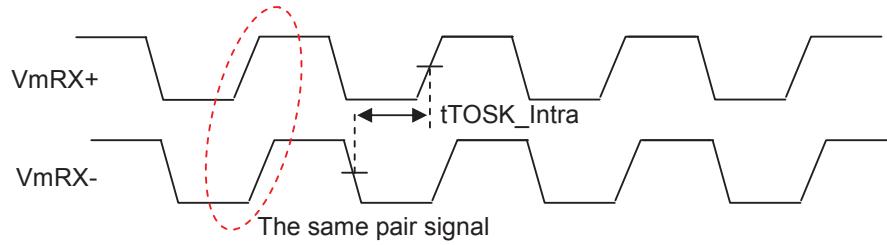

Note (2) V-by-One HS Inter-pair skew

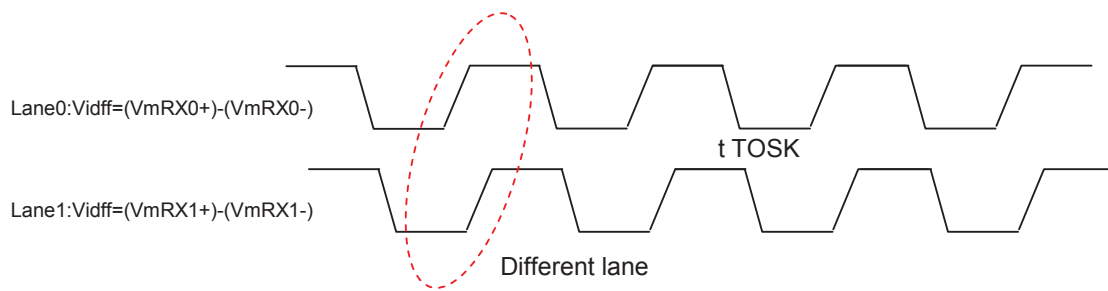

Note (3) The SSCG (Spread spectrum clock generator) is defined as below figures.

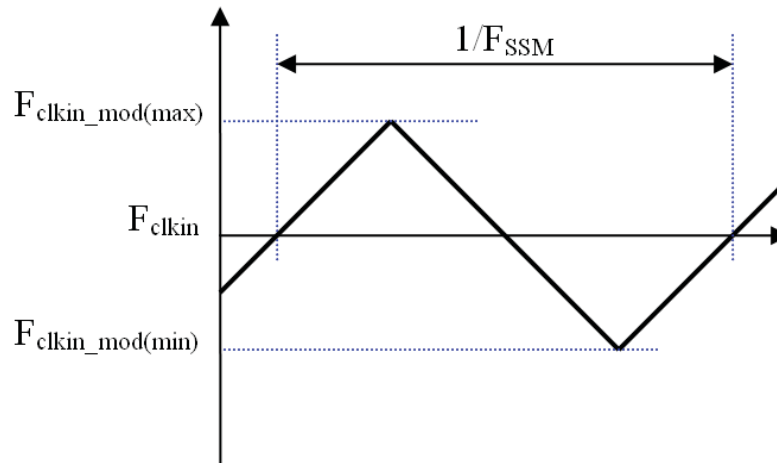

Note (4) The DCLK range at last line of V-blank should be set in 0 to Hdisplay/2

CONFIDENTIAL

4.6 POWER ON/OFF SEQUENCE

The power sequence specifications are shown as the following table and diagram.

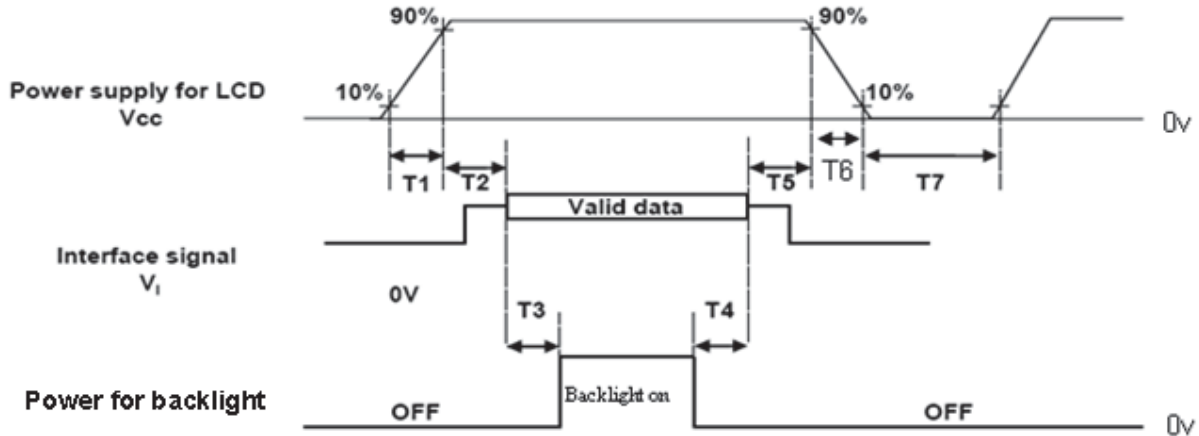

Timing Specifications:

Parameters	Values			Units
	Min	Typ.	Max	
T1	0.5	-	10	ms
T2	0	(30)	50	ms
T3	TBD	TBD	-	ms
T4	TBD	TBD	-	ms
T5	0	(20)	50	ms
T6	TBD	-	TBD	ms
T7	TBD	-	-	ms

Note (1) The supply voltage of the external system for the module input should be the same as the definition of Vcc.

Note (2) When the backlight turns on before the LCD operation of the LCD turns off, the display may momentarily become abnormal screen.

Note (3) In case of VCC = off level, please keep the level of input signals on the low or keep a high impedance.

Note (4) T7 should be measured after the module has been fully discharged between power off and on period.

Note (5) Interface signal shall not be kept at high impedance when the power is on.

Note (6) INX won't take any responsibility for the products which are damaged by the customers not following the Power Sequence.

Note (7) There might be slight electronic noise when LCD is turned off (even backlight unit is also off). To avoid this symptom, we suggest "Vcc falling timing" to follow "t6 spec".

5. OPTICAL CHARACTERISTICS

5.1 TEST CONDITIONS

Item	Symbol	Value	Unit
Ambient Temperature	Ta	25±2	oC
Ambient Humidity	Ha	50±10	%RH
Supply Voltage	VCC	5	V
Input Signal	According to typical value in "3. ELECTRICAL CHARACTERISTICS"		
LED Light Bar Input Current Per Input Pin	IPIN	(150±2.55)	mA
PWM Duty Ratio	D	100	%
LED Light Bar Test Converter	(INX 27 - D089583)		

5.2 OPTICAL SPECIFICATIONS

The relative measurement methods of optical characteristics are shown in 5.2. The following items should be measured under the test conditions described in 5.1 and stable environment shown in Note (5).

Item	Symbol	Condition	Min.	Typ.	Max.	Unit	Note	
Color Chromaticity (CIE 1931)	Red	Rx	$\theta_x=0^\circ, \theta_y=0^\circ$ CS-2000 R=G=B=255 Gray scale	Typ - 0.03	(0.630)	Typ + 0.03	-	(1), (5)
		Ry			(0.341)			
	Green	Gx			(0.310)			
		Gy			(0.626)			
	Blue	Bx			(0.156)			
		By			(0.061)			
	White	Wx			0.313			
		Wy			0.329			
Center Luminance of White (Center of Screen)	Lc		250	300	-	cd/m ²	(4), (5)	
Contrast Ratio	CR		(700)	(1000)	-	-	(2), (5)	
Response Time	T _R	$\theta_x=0^\circ, \theta_y=0^\circ$	-	(1.5)	(2.5)	ms	(3)	
	T _F		-	(3.5)	(5.5)			
White Variation	δW	$\theta_x=0^\circ, \theta_y=0^\circ$ USB2000	-	-	(1.42)	-	(5), (6)	
Viewing Angle	Horizontal	θx +	(80)	(85)	-	Deg.	(1), (5)	
		θx -	(80)	(85)	-			
Viewing Angle	Vertical	θy +	(70)	(80)	---			
		θy -	(70)	(80)	---			

Note (1) Definition of Viewing Angle (θ_x , θ_y):

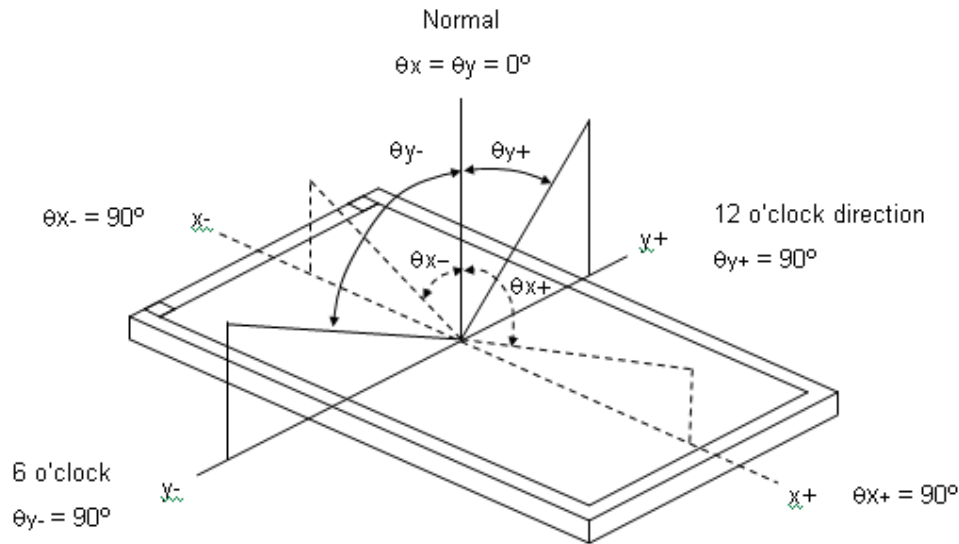

Note (2) Definition of Contrast Ratio (CR):

The contrast ratio can be calculated by the following expression.

$$\text{Contrast Ratio (CR)} = L_{255} / L_0$$

L255: Luminance of gray level 255

L 0: Luminance of gray level 0

$$\text{CR} = \text{CR} (5)$$

CR (X) is corresponding to the Contrast Ratio of the point X at Figure in Note (6).

Note (3) Definition of Gray-to-Gray Switching time :

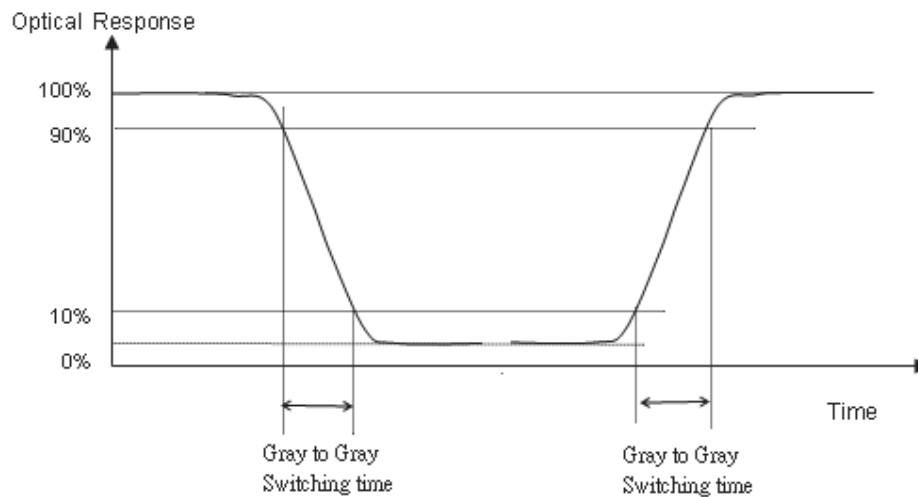

The driving signal means the signal of gray level 0,31,63,95,127,159,191,223 and 255.

Gray to gray average time means the average switching time of gray level 0,31,63,95,127,

159,191,223 and 255 to each other.

CONFIDENTIAL

Note (4) Definition of Luminance of White (L_C):

Measure the luminance of gray level 255 at center point

$$L_C = L(5)$$

$L(x)$ is corresponding to the luminance of the point X at Figure in Note (6).

Note (5) Measurement Setup:

The LCD module should be stabilized at given temperature for 40 minutes to avoid abrupt temperature change during measuring. In order to stabilize the luminance, the measurement should be executed after lighting Backlight for 40 minutes in a windless room.

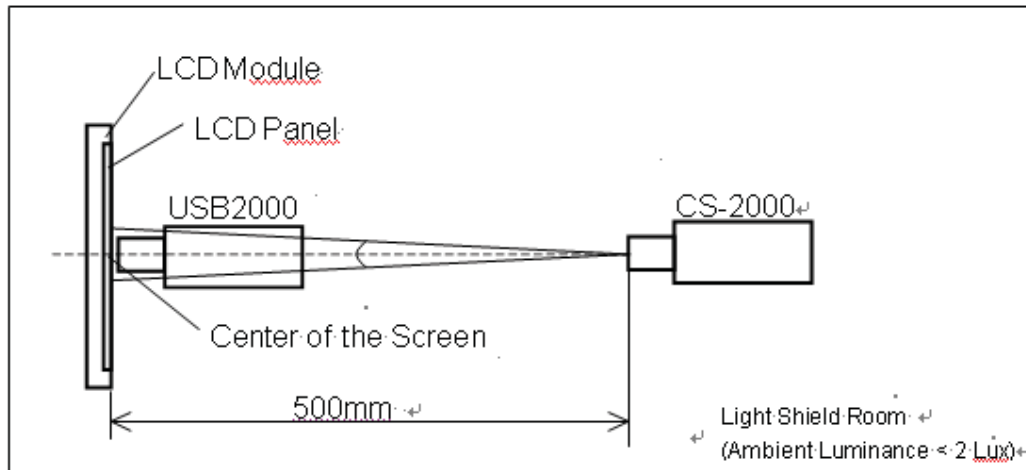

Note (6) Definition of White Variation (δW):

Measure the luminance of gray level 255 at 9 points

$$\delta W = \text{Minimum} [L(1) \sim L(9)] / \text{Maximum} [L(1) \sim L(9)]$$

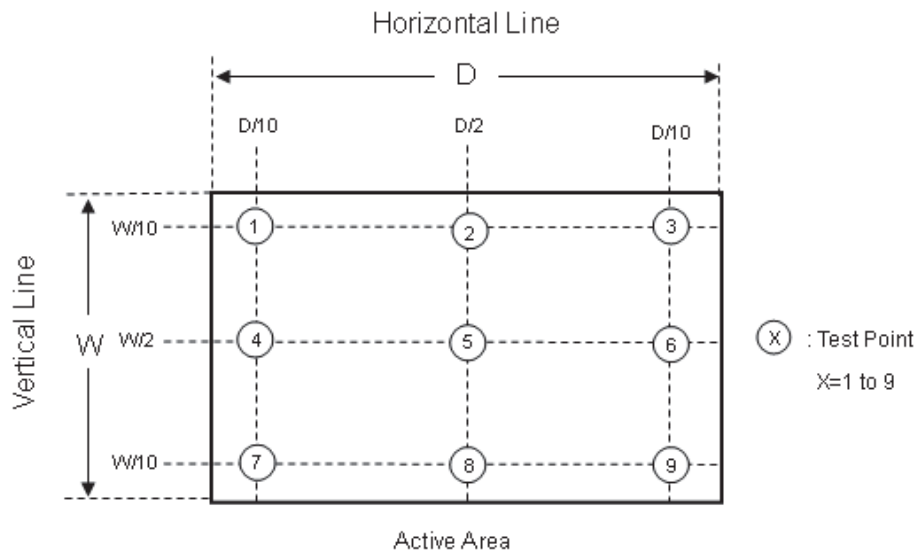

CONFIDENTIAL

6. RELIABILITY TEST ITEM

Items	Required Condition	Note
Temperature Humidity Bias (THB)	Ta= 50°C , 80%RH, 240hours	
High Temperature Operation (HTO)	Ta= 50°C , 240hours	
Low Temperature Operation (LTO)	Ta= 0°C , 240hours	
High Temperature Storage (HTS)	Ta= 60°C , 240hours	
Low Temperature Storage (LTS)	Ta= -20°C , 240hours	
Vibration Test (Non-operation)	Acceleration: 1.5 Grms Wave: Half-sine Frequency: 10 - 300 Hz Sweep: 30 Minutes each Axis (X, Y, Z)	
Shock Test (Non-operation)	Acceleration: 50 G Wave: Half-sine Active Time: 11 ms Direction : ± X, ± Y, ± Z.(one time for each Axis)	
Thermal Shock Test (TST)	-20°C/30min , 60°C / 30min , 100 cycles	
On/Off Test	25°C ,On/10sec , Off /10sec , 30,000 cycles	
ESD (Electro Static Discharge)	Contact Discharge: ± 8KV, 150pF(330Ω)	
	Air Discharge: ± 15KV, 150pF(330Ω)	
Altitude Test	Operation:10,000 ft / 24hours	
	Non-Operation:30,000 ft / 24hours	

Note (1) criteria : Normal display image with no obvious non-uniformity and no line defect.

Note (2) Evaluation should be tested after storage at room temperature for more than two hour

Note (3) At testing Vibration and Shock, the fixture in holding the module has to be hard and rigid enough so that the module would not be twisted or bent by the fixture.

The fixing condition is shown as below:

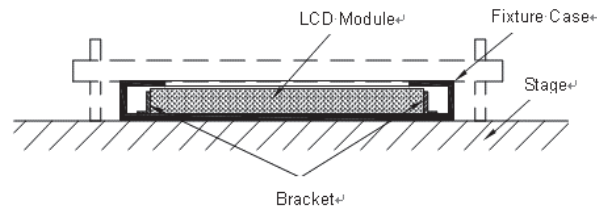

CONFIDENTIAL

7. PACKING

7.1 PACKING SPECIFICATIONS

- (1) 9 LCD modules / 1 Box
- (2) Box dimensions: 713(L) X 429(W) X 453(H) mm
- (3) Weight: approximately: (34) Kg (9 modules per box)

7.2 PACKING METHOD

(1) Carton Packing should have no failure in the following reliability test items.

Test Item	Test Conditions	Note
Vibration	ISTA STANDARD Random, Frequency Range: 1 – 200 Hz Top & Bottom: 30 minutes (+Z), 10 min (-Z), Right & Left: 10 minutes (X) Back & Forth 10 minutes (Y)	Non Operation
Dropping Test	1 Angle, 3 Edge, 6 Face, ISTA 31cm	Non Operation

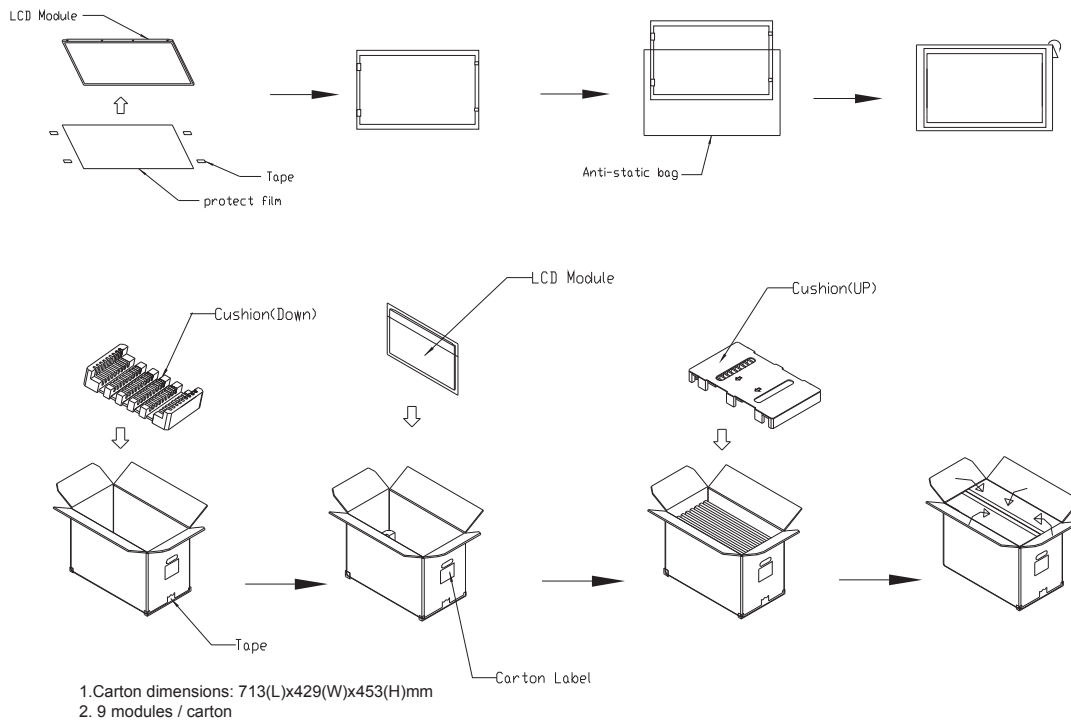
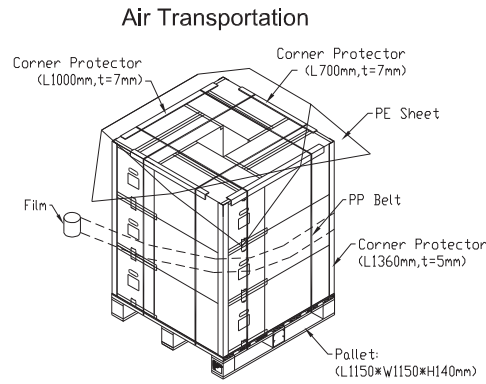

Figure. 7-1 Packing method

CONFIDENTIAL

7.3 PALLET

For ocean shipping



For air transport

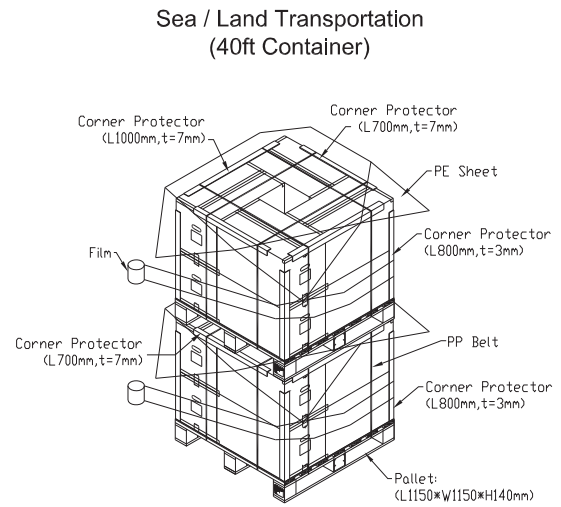
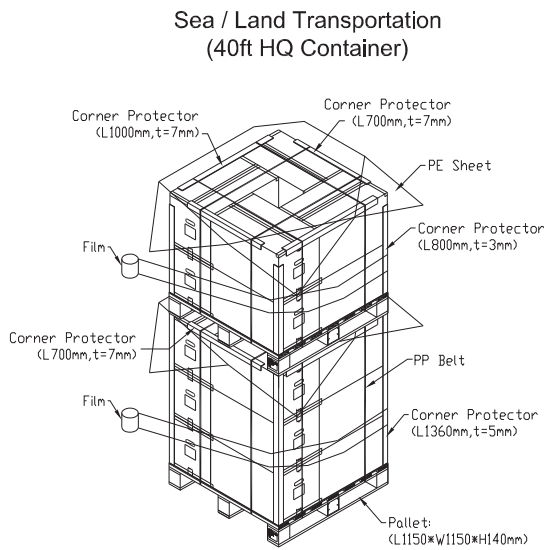
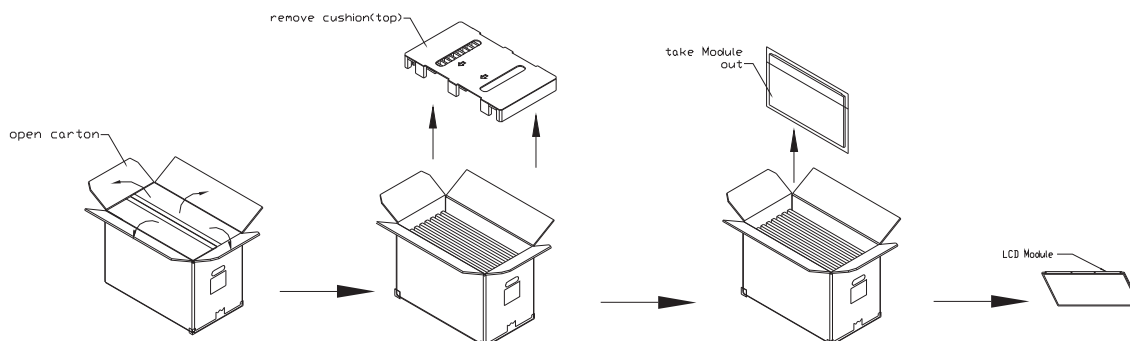

Figure. 7-2 Packing method

CONFIDENTIAL

7.4 UN-PACKING METHOD



CONFIDENTIAL

8. INX MODULE LABEL

The barcode nameplate is pasted on each module as illustration, and its definitions are as following explanation.

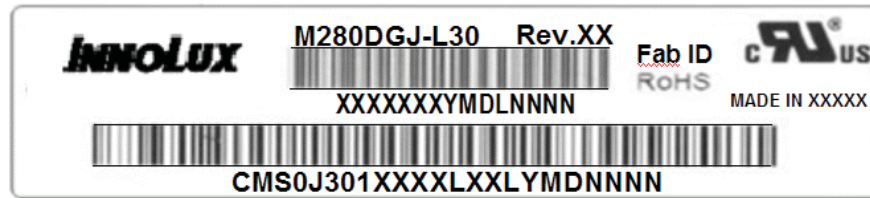

- (a) Model Name: M280DGJ-L30
- (b) Revision: Rev. XX, for example: A0, A1... B1, B2... or C1, C2...etc.
- (c) InnoLux barcode definition:

Serial ID: XX-XX-X-XX-YMD-L-NNNN

Code	Meaning	Description
XX	InnoLux internal use	-
XX	Revision	Cover all the change
X	InnoLux internal use	-
XX	InnoLux internal use	-
YMD	Year, month, day	Year: 0~9, 2001=1, 2002=2, 2003=3...2010=0, 2011=1, 2012=2... Month: 1~12=1, 2, 3, ~, 9, A, B, C Day: 1~31=1, 2, 3, ~, 9, A, B, C, ~, W, X, Y, exclude I, O, and U.
L	Product line #	Line 1=1, Line 2=2, Line 3=3, ...
NNNN	Serial number	Manufacturing sequence of product

- (d) Customer's barcode definition:

Serial ID: CM-S0J30-X-X-X-XX-L-XX-L-YMD-NNNN

Code	Meaning	Description
CM	Supplier code	INX=CM
S0J30	Model number	M280DGJ-L30= S0J30
X	Revision code	Non ZBD: 1,2,~,8,9 / ZBD: A~Z
X	Source driver IC code	Century=1, CLL=2, Demos=3, Epson=4, Fujitsu=5, Himax=6, Hitachi=7, Hynix=8, LDI=9, Matsushita=A, NEC=B, Novatec=C, OKI=D, Philips=E, Renesas=F, Samsung=G, Sanyo=H, Sharp=I, TI=J, Topro=K, Toshiba=L, Windbond=M, ILITEK=Q, Fiti=Y, None IC =Z
X	Gate driver IC code	OKI=D, Philips=E, Renesas=F, Samsung=G, Sanyo=H, Sharp=I, TI=J, Topro=K, Toshiba=L, Windbond=M, ILITEK=Q, Fiti=Y, None IC =Z
XX	Cell location	Tainan Taiwan=TN, Ningbo China=CN, Hsinchu Taiwan=SC
L	Cell line #	1,2,~,9,A,B,~,Y,Z
XX	Module location	Tainan, Taiwan=TN ; Ningbo China=NP, Shenzhen China=SH
L	Module line #	1,2,~,9,A,B,~,Y,Z
YMD	Year, month, day	Year: 0~9, 2001=1, 2002=2, 2003=3...2010=0, 2011=1, 2012=2... Month: 1~12=1, 2, 3, ~, 9, A, B, C Day: 1~31=1, 2, 3, ~, 9, A, B, C, ~, T, U, V
NNNN	Serial number	By LCD supplier

CONFIDENTIAL

(e) FAB ID(UL Factory ID):

Region	Factory ID
TWINX	GEMN
NBCMI	LEOO
NBCMI	VIRO
NBCME	CANO
NHCM1	CAPG

9. PRECAUTIONS

9.1 ASSEMBLY AND HANDLING PRECAUTIONS

- (1) Do not apply rough force such as bending or twisting to the module during assembly.
- (2) To assemble or install module into user's system can be only in clean working areas. The dust and oil may cause electrical short or worsen the polarizer.
- (3) It's not permitted to have pressure or impulse on the module because the LCD panel and Backlight will be damaged.
- (4) Always follow the correct power sequence when LCD module is connecting and operating. This can prevent damage to the CMOS LSI chips during latch-up.
- (5) Do not pull the I/F connector in or out while the module is operating.
- (6) Do not disassemble the module.
- (7) Use a soft dry cloth without chemicals for cleaning, because the surface of polarizer is very soft and easily scratched.
- (8) It is dangerous that moisture come into or contacted the LCD module, because moisture may damage LCD module when it is operating.
- (9) High temperature or humidity may reduce the performance of module. Please store LCD module within the specified storage conditions.
- (10) When ambient temperature is lower than 10°C may reduce the display quality. For example, the response time will become slowly.

9.2 STORAGE PRECAUTIONS

- (1) Do not leave the module in high temperature, and high humidity for a long time. It is highly recommended to store the module with temperature from 0°C to 35°C and relative humidity of less than 70%
- (2) Do not store the TFT – LCD module in direct sunlight
- (3) The module should be stored in dark place. It is prohibited to apply sunlight or fluorescent light in storing

9.3 OPERATION PRECAUTIONS

- (1) The LCD product should be operated under normal condition.

Normal condition is defined as below :

Temperature : 20±15°C

Humidity: 65±20%

Display pattern : continually changing pattern(Not stationary)

CONFIDENTIAL

(2) If the product will be used in extreme conditions such as high temperature, high humidity, high altitude, display pattern or operation time etc... It is strongly recommended to contact INX for application engineering advice. Otherwise, its reliability and function may not be guaranteed.

9.4 SAFETY PRECAUTIONS

- (1) If the liquid crystal material leaks from the panel, it should be kept away from the eyes or mouth. In case of contact with hands, skin or clothes, it has to be washed away thoroughly with soap.
- (2) After the module's end of life, it is not harmful in case of normal operation and storage.

9.5 SAFETY STANDARDS



The LCD module should be certified with safety regulations as follows:

Requirement	Standard	remark
UL	UL60950-1:2006 or Ed.2:2007	
cUL/CSA	CAN/CSA C22.2 No.60950-1-03 or 60950-1-07	
CB	IEC60950-1:2005 / EN60950-1:2006+ A11:2009	

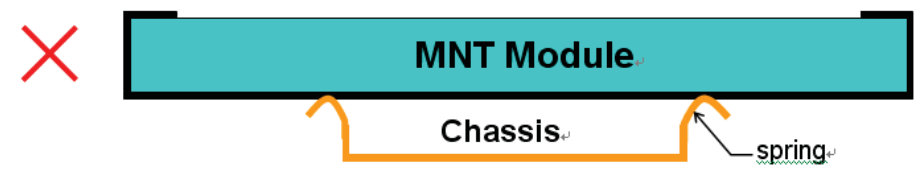

9.6 OTHER

When fixed patterns are displayed for a long time, remnant image is likely to occur.

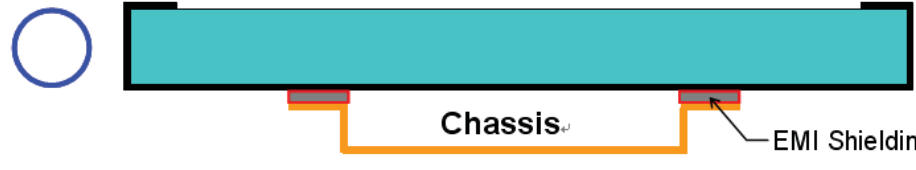
Appendix 1. SYSTEM COVER DESIGN NOTICE

1.	Set Chassis and MNT Module touching Mode
✘	 <p>MNT Module Chassis spring</p>
△	 <p>MNT Module Chassis Flat sheetmetal</p>
○	 <p>MNT Module Chassis EMI Shielding Gasket (Tape/Sponge)</p>
Definition	<p>a) To prevent from abnormal display & white spot after Mechanical test, it is not recommended to used spring type chassis.</p> <p>b) We suggest the contact mode between Chassis and Module rear cover is Tape/Sponge, second is Flat sheetmetal type chassis (Don't interference from flat sheetmetal of chassis to rear cover of Module).</p>

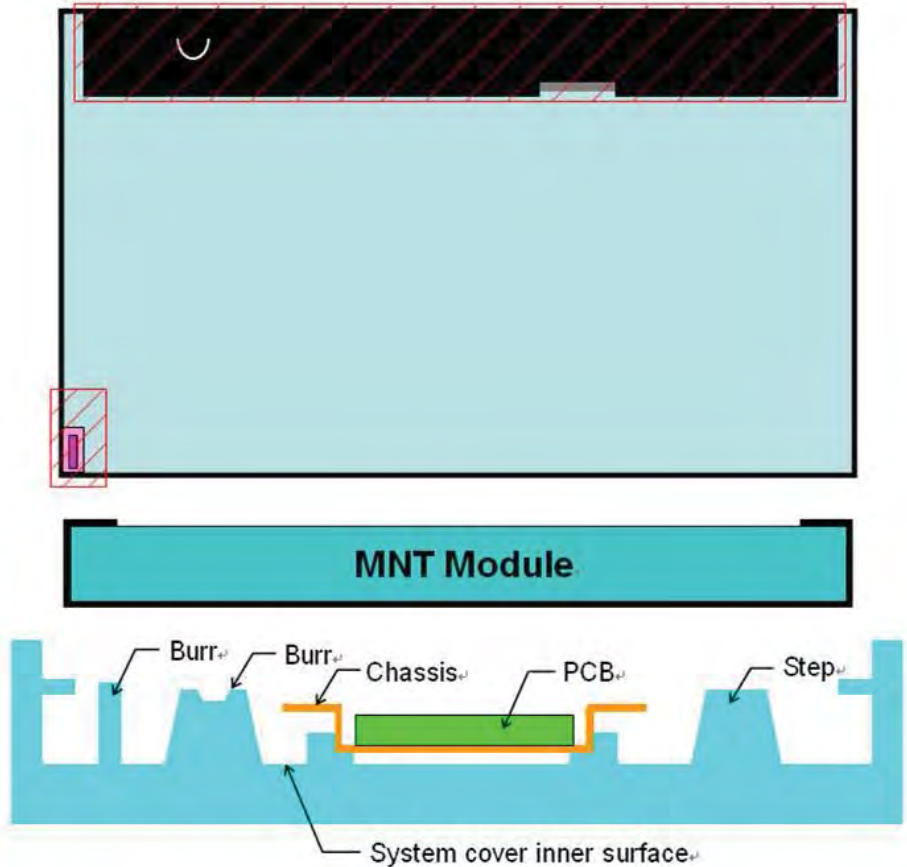
CONFIDENTIAL

3	System inner surface examination
	
Definition	<p>a). Burr at logo edge, step, protrusion or PCB board will easily cause white spot.</p> <p>b). Keeping flat surface underneath module is recommended.</p> <p>c). The area () on Module PCBA and Light bar connector should keep at least 1mm gap to any structure with System cover inner surface.</p>

CONFIDENTIAL

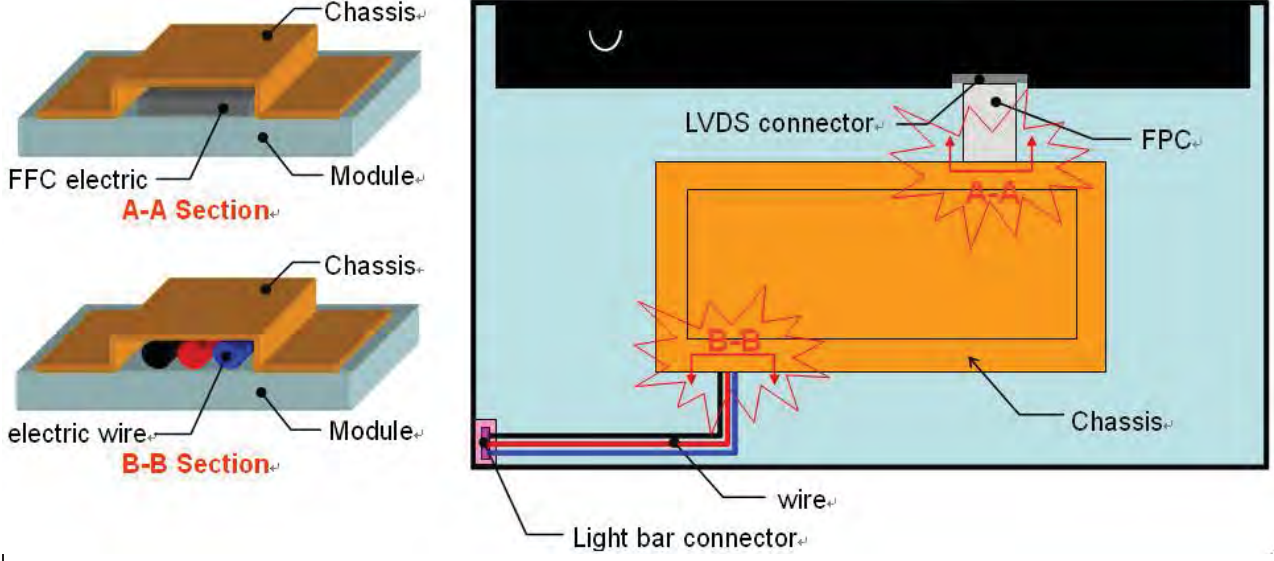
4	The overlapping part on System's Chassis and electric wire needs gap structure.
	
Definition	The overlapping part on System's Chassis and electric wire (FPC、FFC and wire) needs gap structure to avoid display of white spot by pressing overlapping part cause interference.

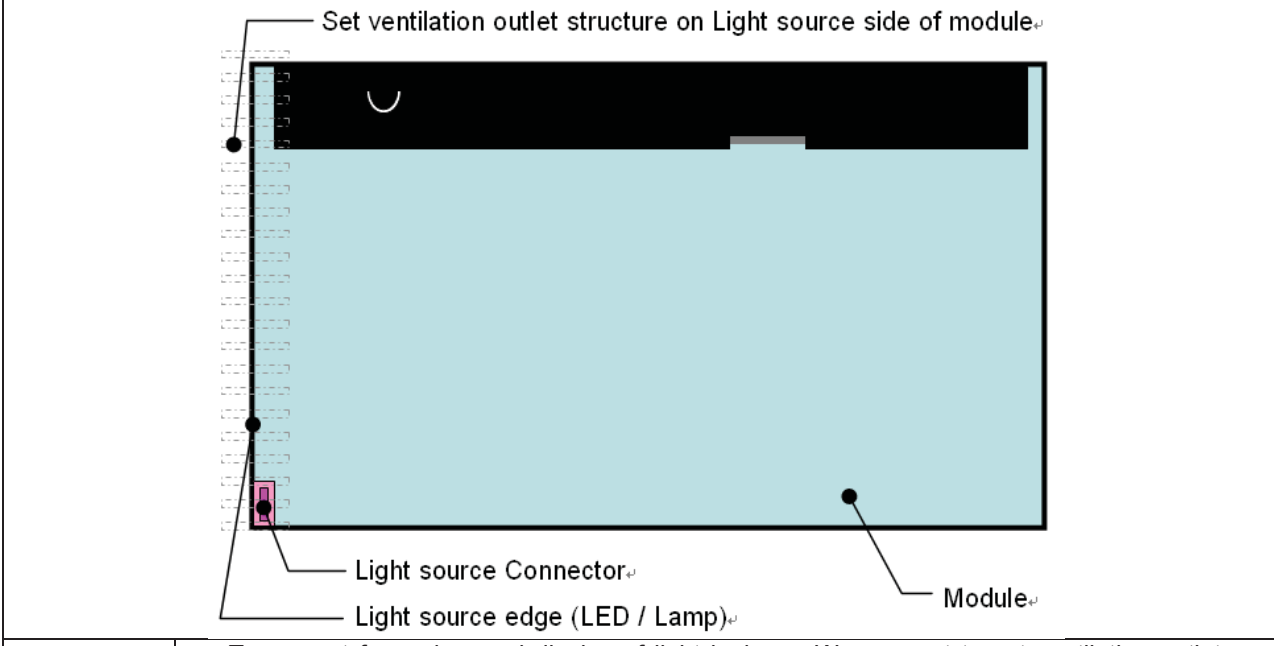
5	System cover's ventilation outlet structure
	
Definition	To prevent from abnormal display of light leakage, We suggest to set ventilation outlet structure on side of Module Light bar in system cover inner surface.

Appendix 2. OUTLINE DRAWING

CONFIDENTIAL

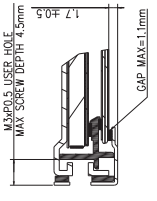
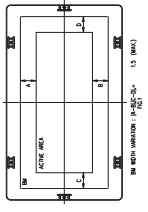

SECTION USER_HOLE--USER_HOLE SCALE 4:1

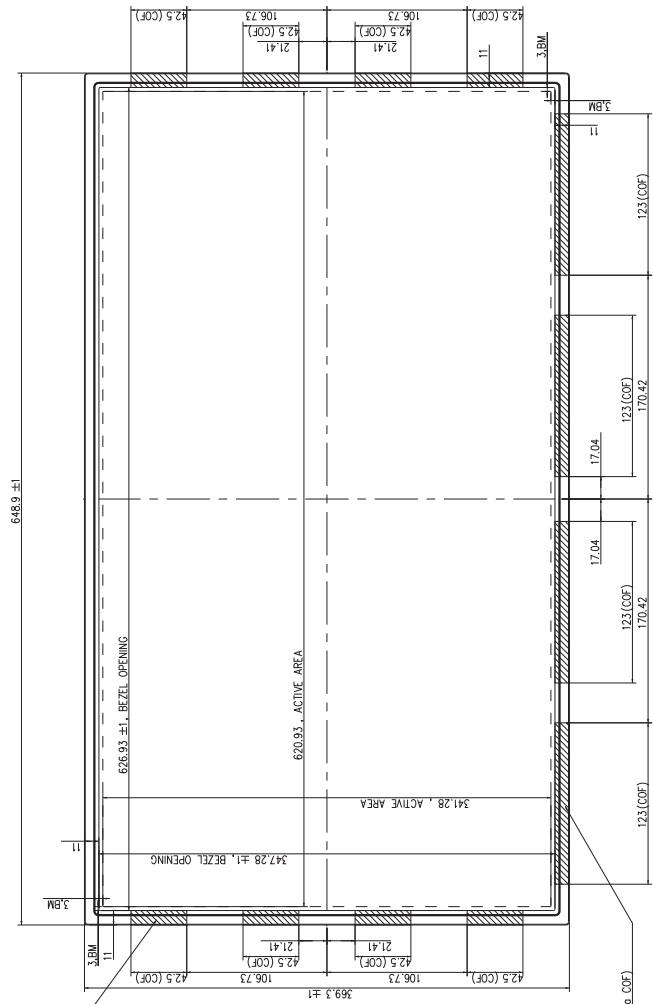
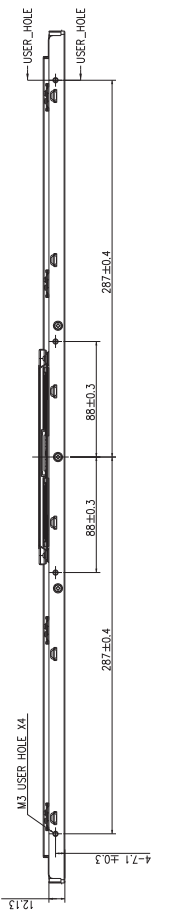

Scan COF Position (SI mechanical structure should not touch the positions of Date COF)

Date COF Position (SI mechanical structure should not touch the positions of Date COF)

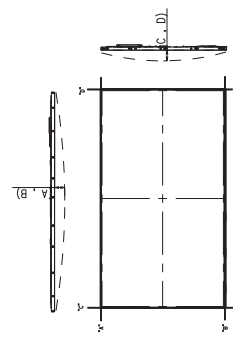
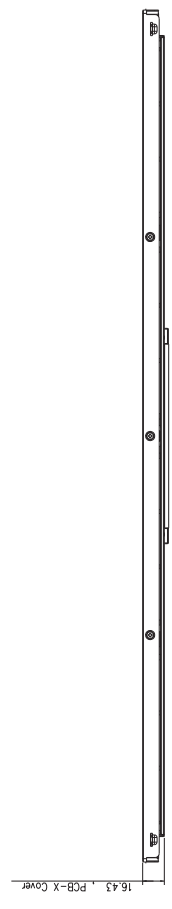
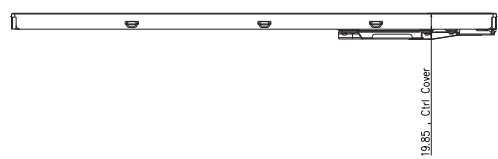

SCALE 4:1

- NOTES:
- UNLESS OTHERWISE SPECIFY TOLERANCE IS ±0.1mm.
 - UNLESS OTHERWISE SPECIFY MOUNTING AREA POSITION.
 - CONNECTOR TYPE: CON-1; CON WF23-400-513C or P-TWO 187099-51221; OR EQUIVALENT
 - SCREW: TORX; TORX WF13-406-063N; OR EQUIVALENT
 - M3.2-459-2.59mm PITCH 0.5 / MACHINE. MAX. TORQUE=7 KGF-CM*10 TIMES. MAX.DEPTH=4.5mm

REV	EC NUMBER	DESCRIPTION	DATE
1		First Release	2012/07/20

DESIGNER	DATE	SCALE	REV
DESIGNED	11/18/12	1:1	1
CHECKED	11/18/12	1:1	1
DESIGNED	11/18/12	1:1	1

CONFIDENTIAL

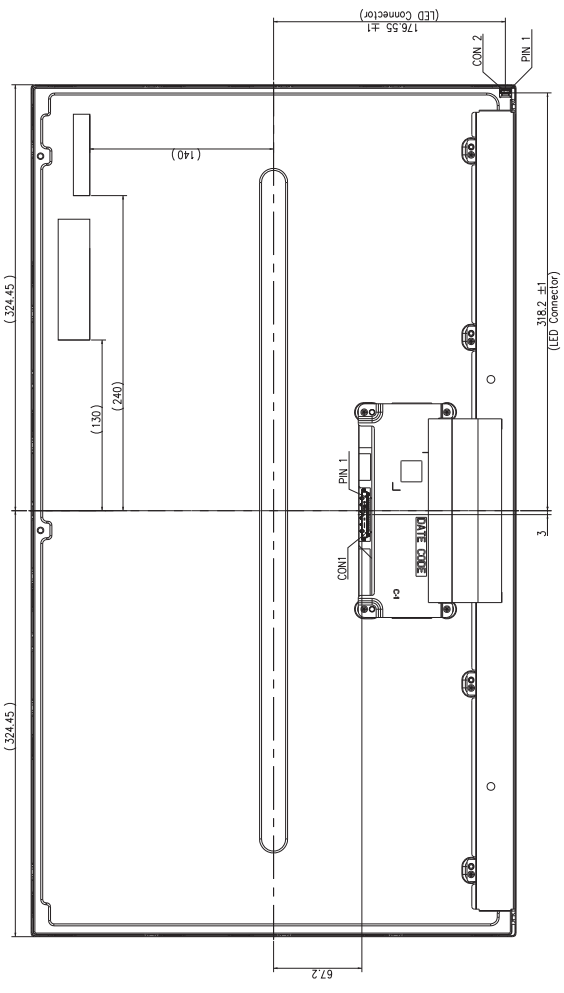

- NOTES:
 1. UNLESS OTHERWISE SPECIFY TOLERANCE IS ±1.0mm.
 2. CONNECTOR TYPE:
 CON. 1: FCN WFS-400-5130, or P-TWO 187059-51221, OR EQUIVALENT
 CON. 2: FCN WFS-400-5083N, OR EQUIVALENT
 3. SCREW HOLES TYPE:
 M3: 2.459-2.599mm, PITCH 0.5 / MACHINE, MAX. TORQUE=7 KGF-CM*10 TIMES, MAX. DEPTH=4.5mm

REV.	LC NUMBER	DESCRIPTION	DATE
1		First Release	2010/01/01

DIMENSIONAL TOLERANCE	
RANGE(mm)	TOL. ±
0-6	±0.1
6-30	±0.15
30-150	±0.2
150-300	±0.25
300-600	±0.3
600-1000	±0.4
>1000	±0.5

REV.	DATE	BY	CHKD.	APP'D.
1	2010/01/01	Jerry Yen	Jerry Yen	Jerry Yen



Displays

US Micro Products is an industrial distributor specializing in engineered display solutions. We dedicate ourselves to providing the best in displays for the medical, industrial, gaming, automotive, aerospace, military and consumer markets.

OLEDs



TFT Display



Open Frame Monitors



Passive LCDs



Multitouch



Touch Screen



As our customer, you receive expert knowledge, support and service. Our technical sales staff and experienced design engineers provide answers to your questions and engineered solutions to meet your display needs.

Peripheral Devices

Our full line of peripheral devices includes keyboards, trackballs and printers. These rugged industrial products are designed to meet the rigorous demands of your equipment and are available in a variety of standard and custom options.

Keyboards



Trackballs



Aerospace Trackballs



Printers

